

PART NO	A DIM	CABLE	1-9	10-24	25-49	50-99	100+
307 PZ	.143	.141	\$26.50	\$25.50	\$23.00	\$21.75	\$20.50
307-1 PZ	.0875	.085	\$26.50	\$25.50	\$23.00	\$21.75	\$20.50
307-3 PZ	.048	.047	\$28.50	\$27.50	\$25.00	\$23.75	\$22.50

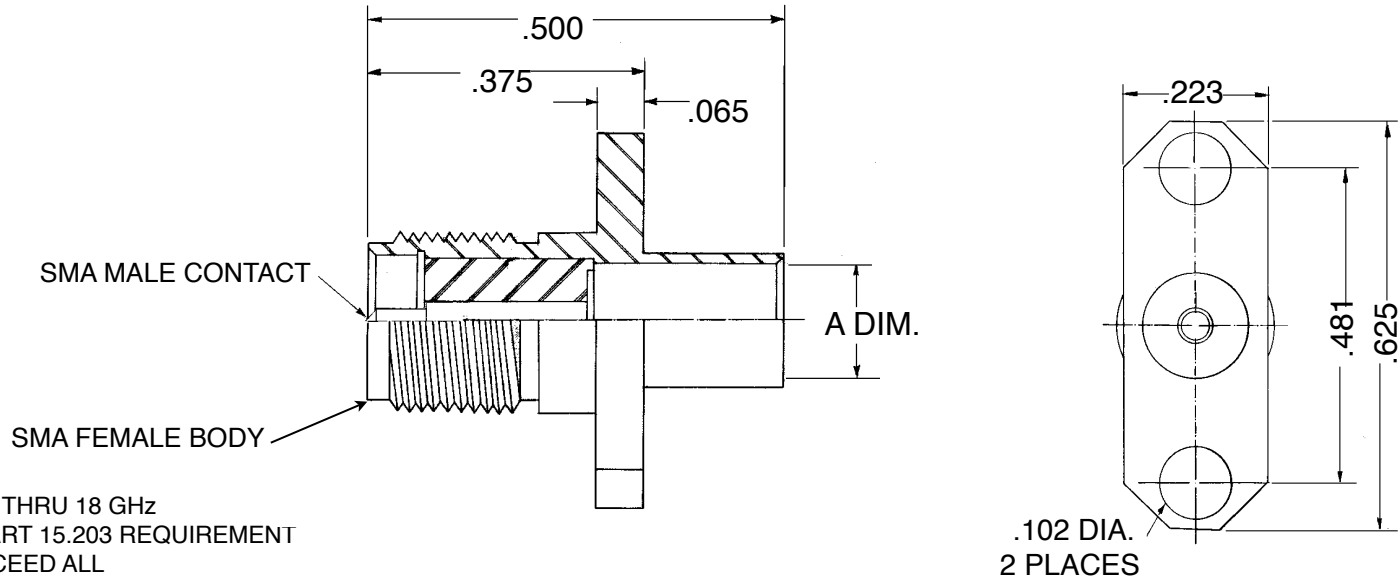

6. VSWR NOT TO EXCEED 1.25 :1 THRU 18 GHZ
5. CONNECTOR TO MEET FCC PART 15.203 REQUIREMENT
4. CONNECTOR TO MEET OR EXCEED ALL SPECIFICATIONS PER MIL-39012
3. FINISH:
 BODY: GOLD PER MIL-G-45204:
 OVER NICKEL PER QQ-N-290
 CONTACT: GOLD PER MIL-G-45204: TYPE II,
 CLASS 2, OVER COPPER PER MIL-C-14550, CLASS 4
2. MATERIAL:
 BODY: STAINLESS STL PER QQ-S-764 TYPE 303
 CONTACT: BERYL. COPPER PER QQ-C-530
 INSULATOR: TEFLON PER MIL-P-19468A
1. MATING DIMS IN ACCORDANCE WITH MIL-STD-348

NOTES :

NOTICE

This drawing embodies a CONFIDENTIAL proprietary design originated by United Microwave Products, Inc., and all design, manufacturing, reproduction, use and sale rights regarding the same are expressly reserved. It is submitted under a confidential relationship for a specified purpose and the recipient agrees by accepting this drawing not to supply or disclose any information regarding it to any unauthorized person or to incorporate in other projects any special feature peculiar to this design. All patent rights hereto are expressly reserved by United Microwave Products Inc.

TOLERANCES AND NOTES EXCEPT AS NOTED DIMENSIONS ARE IN INCHES

LINEAR XX ± .015 ANGULAR ± 1/2 ° FRACTION ± 1/32
 XXX ± .005

1. MACHINE FINISH $\sqrt{63}$ RMS
2. BREAK ALL SHARP EDGES .002
3. ALL MACHINED FILLLETS
4. ALL MACHINED SURFACES SQUARE TO RESPECTIVE AXIS WITHIN .003 PER INCH.
5. MACHINED DIAMETERS TO BE .
 CONCENTRIC WITHIN .002 - .003 T.I.R.
6. DIMENSIONS TO BE MET BEFORE PLATING.
7. CHAMFER ALL THDS. 45 DEGREES
8. THREADS PER H-2B
9. REMOVE FRAYED EDGES ON TEFLON.
10. REMOVE ALL BURRS.

UNITED MICROWAVE PRODUCTS Inc.

POLARIZED SMA FEMALE 2 HOLE FLANGE
 SMA MALE CONTACT SEMI-RIGID CABLE

307 PZ

WEIGHT

N/A

SCALE

NONE

MATERIAL

SIZE

SPECIFICATION

PROCUREMENT

APPR.

ENG.

CHK.

DR.