

PART NO.	1-9	10-24	25-49	50-99	100+
1544-687 O	\$17.50	\$16.75	\$16.25	\$15.75	\$15.25

5. VSWR NOT TO EXCEED 1.20:1 FROM DC TO 11.0 GHZ & 1.30:1 FROM 11GHZ TO 18 GHZ
4. CONNECTOR TO MEET OR EXCEED ALL SPECIFICATIONS PER MIL-39012
3. FINISH:  
BODY: NICKLE PER QQ-N-290  
CONTACT: GOLD PER MIL-G-45204: TYPE II, CLASS 2, OVER COPPER PER MIL-C-14550, CLASS 4
2. MATERIAL:  
BODY: BRASS PER QQ-B-626  
CONTACT: BERYL. COPPER PER QQ-C-530  
INSULATOR: TEFLON PER MIL-P-19468A
1. MATING DIMS IN ACCORDANCE WITH MIL-STD-348

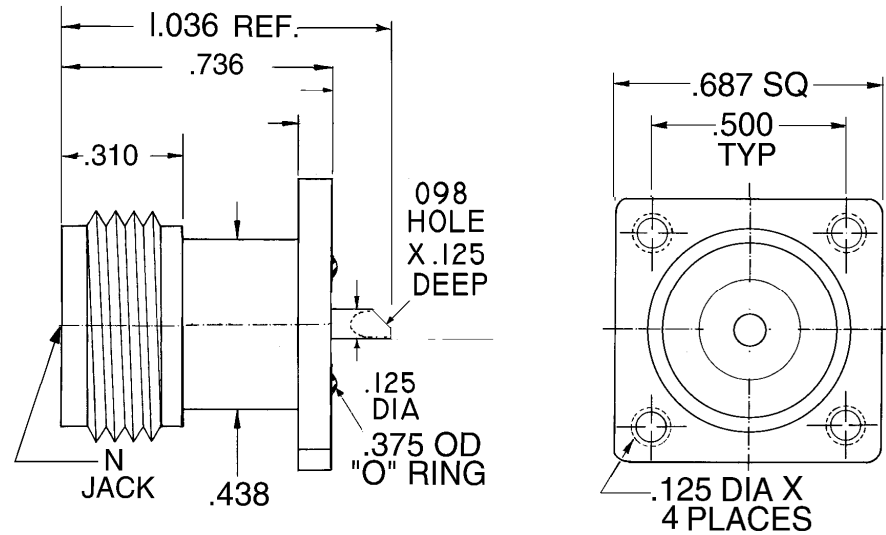

NOTES :

**NOTICE**

This drawing embodies a CONFIDENTIAL proprietary design originated by United Microwave Products, Inc., and all design, manufacturing, reproduction, use and sale rights regarding the same are expressly reserved. It is submitted under a confidential relationship for a specified purpose and the recipient agrees by accepting this drawing not to supply or disclose any information regarding it to any unauthorized person or to incorporate in other projects any special feature peculiar to this design. All patent rights hereto are expressly reserved by United Microwave Products Inc.

**TOLERANCES AND NOTES EXCEPT AS NOTED DIMENSIONS ARE IN INCHES**

LINEAR .XX ± .015 ANGULAR ± 1/2 ° FRACTION ± 1/32  
XXX ± .005

1. MACHINE FINISH  $\sqrt{37}$  RMS
2. BREAK ALL SHARP EDGES .002
3. ALL MACHINED FILLETS
4. ALL MACHINED SURFACES SQUARE TO RESPECTIVE AXIS WITHIN .003 PER INCH.
5. MACHINED DIAMETERS TO BE CONCENTRIC WITHIN .002 - .003 T.I.R.
6. DIMENSIONS TO BE MET BEFORE PLATING.
7. CHAMFER ALL THDS. 45 DEGREES
8. THREADS PER H-2B
9. REMOVE FRAYED EDGES ON TEFLON.
10. REMOVE ALL BURRS.

UNITED MICROWAVE PRODUCTS Inc.

**N FEMALE TNC O-RING FLANGE MOUNT  
SOLDER POT CAPTIVE CONTACT**

**1544-687 O**

WEIGHT	SCALE
N/A	NONE

MATERIAL	SIZE	SPECIFICATION	PROCUREMENT
		APPR.	
		ENG.	
		CHK.	
		DR.	