

PART NO.	1-9	10-24	25-49	50-99	100+
1521-SF	\$152.00	\$145.00	\$137.00	\$123.00	\$122.00

5. VSWR NOT TO EXCEED 1.20:1 FROM DC TO 11.0 GHz & 1.30:1 FROM 11GHz TO 18 GHz
4. ADAPTOR TO MEET OR EXCEED ALL SPECIFICATIONS PER MIL-39012
3. FINISH:
 BODY : PASSIVATE PER QQ-P-35
 CONTACT: GOLD PER MIL-G-45204: TYPE II, CLASS 2, OVER COPPER PER MIL-C-14550, CLASS 4
 COUPLING NUT: PASSIVATE PER QQ-P-35
2. MATERIAL:
 BODY: STAINLESS STL PER QQ-S-763 TYPE 303
 CONTACT: BERYL. COPPER PER QQ-C-530 & BRASS PER QQ-B-626
 COUPLING NUT: STAINLESS STL PER QQ-S-763 TYPE 303
 INSULATOR: TEFLON PER MIL-P-19468A
1. MATING DIMS IN ACCORDANCE WITH MIL-STD-348

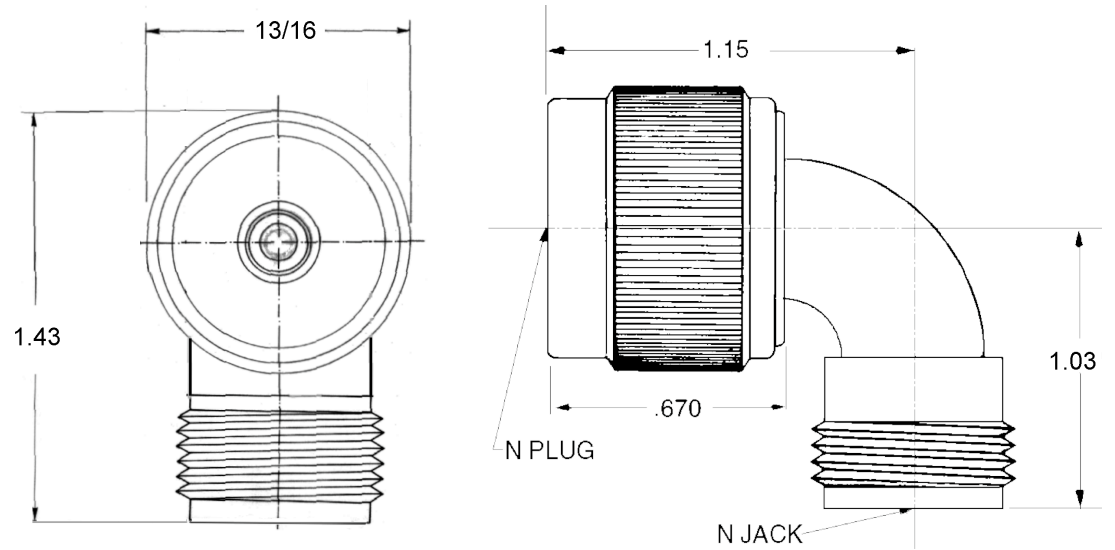

NOTES :

<p>NOTICE</p> <p>This drawing embodies a CONFIDENTIAL proprietary design originated by United Microwave Products, Inc., and all design, manufacturing, reproduction, use and sale rights regarding the same are expressly reserved. It is submitted under a confidential relationship for a specified purpose and the recipient agrees by accepting this drawing not to supply or disclose any information regarding it to any unauthorized person or to incorporate in other projects any special feature peculiar to this design. All patent rights hereto are expressly reserved by United Microwave Products Inc.</p>		<p>TOLERANCES AND NOTES EXCEPT AS NOTED</p> <p>DIMENSIONS ARE IN INCHES</p> <p>LINEAR XX ± .030 ANGULAR ± 1/2 ° FRACTION ± 1/32</p> <p>1. MACHINE FINISH $\sqrt{32}$ RMS</p> <p>2. BREAK ALL SHARP EDGES .002</p> <p>3. ALL MACHINED FILLETS</p> <p>4. ALL MACHINED SURFACES SQUARE TO RESPECTIVE AXIS WITHIN .003 PER INCH.</p> <p>5. MACHINED DIAMETERS TO BE .002 - .003 T.I.R. CONCENTRIC WITHIN .002 - .003 T.I.R.</p> <p>6. DIMENSIONS TO BE MET BEFORE PLATING.</p> <p>7. CHAMFER ALL THDS .45 DEGREES</p> <p>8. THREADS PER H-2B</p> <p>9. REMOVE FRAYED EDGES ON TEFLON.</p> <p>10. REMOVE ALL BURRS.</p>							
				MATERIAL		SIZE		SPECIFICATION	
WEIGHT		SCALE		<p>UNITED MICROWAVE PRODUCTS Inc.</p> <p>N PLUG to N JACK RIGHT ANGLE</p>				APPR.	
								ENG.	
								CHK.	
								DR.	
								1521SF	