

- 5. VSWR NOT TO EXCEED 1.25 :1 THRU 18 GHz
- 4. ADAPTOR TO MEET OR EXCEED ALL SPECIFICATIONS PER MIL-39012
- 3. FINISH:  
 BODY AND COUPLING NUT: PASSIVATE PER QQ-P-35  
 CONTACT: GOLD PER MIL-G-45204: TYPE II, CLASS 2, OVER COPPER PER MIL-C-14550, CLASS 4
- 2. MATERIAL:  
 BODY: STAINLESS STL PER PER QQ-S-764 TYPE 303  
 COUPLING NUT STAINLESS STL PER QQ-S-764 TYPE 303  
 CONTACT: BERYL. COPPER PER QQ-C-530  
 INSULATOR: TEFLON PER MIL-P-19468A
- 1. MATING DIMS IN ACCORDANCE WITH MIL-STD-348

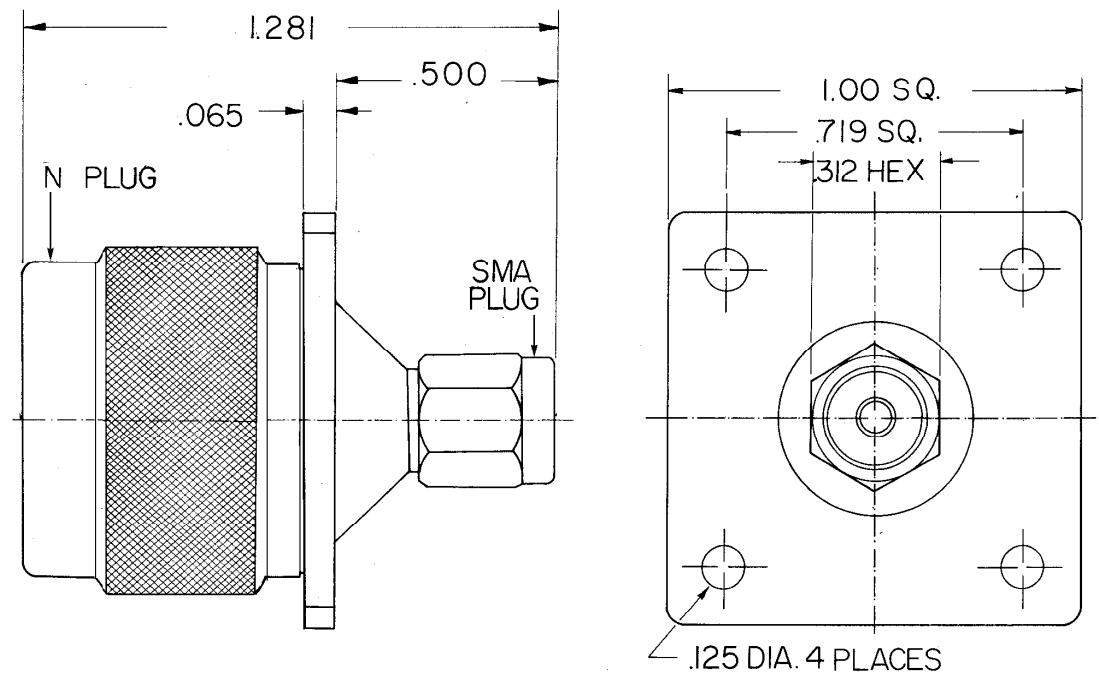

NOTES :

PART NO.	1-9	10-24	25-49	50-99	100+
1405	\$40.75	\$38.75	\$37.25	\$35.50	\$33.50

NOTICE	
This drawing embodies a CONFIDENTIAL proprietary design originated by United Microwave Products, Inc., and all design, manufacturing, reproduction, use and sale rights regarding the same are expressly reserved. It is submitted under a confidential relationship for a specified purpose and the recipient agrees by accepting this drawing not to supply or disclose any information regarding it to any unauthorized person or to incorporate in other projects any special feature peculiar to this design. All patent rights hereto are expressly reserved by United Microwave Products Inc.	
WEIGHT	SCALE
N/A	NONE

TOLERANCES AND NOTES EXCEPT AS NOTED
DIMENSIONS ARE IN INCHES
LINEAR XX ± .015 ANGULAR ± 1/2 ° FRACTION ± 1/32 XXX ± .005
1. MACHINE FINISH $\sqrt{32}$ RMS
2. BREAK ALL SHARP EDGES .002
3. ALL MACHINED FILLETS
4. ALL MACHINED SURFACES SQUARE TO RESPECTIVE AXIS WITHIN .003 PER INCH.
5. MACHINED DIAMETERS TO BE .002 - .003 T.I.R. CONCENTRIC WITHIN .002 - .003 T.I.R.
6. DIMENSIONS TO BE MET BEFORE PLATING.
7. CHAMFER ALL THDS .45 DEGREES
8. THREADS PER H-2B
9. REMOVE FRAYED EDGES ON TEFLON.
10. REMOVE ALL BURRS.

UNITED MICROWAVE PRODUCTS Inc.					
N PLUG TO SMA PLUG PANEL MOUNT					

SPECIFICATION		PROCUREMENT	
APPR.			
ENG.			
CHK.			
DR.			
		1405	